

Model A - 5.6 K Factor

Upright, Pendent, Recessed Pendent, Standard Response, Quick Response



Description

The Model A Series PS001/PS002/PS004/PS005 (Glass Bulb Type) Standard Orifice, standard and quick response. The Model A Upright Sprinkler Identification Number (SIN) PS001(standard) PS005(quick) and Pendent Sprinkler Identification Number (SIN) PS002(standard) PS004(quick). The design incorporates state-of-the-art, heat responsive, frangible glass bulb design (standard or quick response) for prompt, precise operation. The forged frame is more streamlined and attractive than traditional sand cast frames. It is cast with a hex-shaped wrench to allow easy tightening from different angles. This sprinkler is available in various temperature ratings (See Chart on Pg.4) and finishes to meet many design requirements. The recessed Pendent should be utilized with a Model A recessed escutcheon which provides up 3/4" of adjustments. All Protector Sprinklers are manufactured using the time proven Belleville seal used exclusively by all major manufactures to ensure longevity and safe operation.

Operation

The operating mechanism is a frangible glass bulb which contains a heat responsive liquid. During a fire, the ambient temperature rises causing the liquid in the bulb to expand. When the ambient temperature reaches the rated temperature of the sprinkler, the bulb shatters. As a result, the waterway is cleared of all sealing parts and water is discharged towards the deflector. The deflector is designed to distribute the water in a pattern that is most effective in controlling the fire.

Warnings

The Protector Model A Series must be installed and maintained in compliance with this document. Depressurize and drain the piping system before attempting to install, remove, or adjust any Protector Sprinklers. Failure to do so may impair the performance of these sprinklers. The owner is responsible for maintaining the fire protection system and devices in operation.

Technical Specification

Model SIN: PS001, PS002 Standard Response
 PS004, PS005 Quick Response
 Style: PS001, PS005 Upright Sprinkler
 PS002, PS004 Pendent Sprinkler
 K-Factor: 5.6 Imp (80S.I)
 RTI: Standard 90 (m·s)^{1/2}, Quick 33 (m·s)^{1/2}
 Approvals: See Chart on Pg. 4
 Nominal Working Thread: 1/2" NPT (15mm)
 Maximum Working Pressure: 175 PSI (1200kPa)
 Factory Hydrostatic Test: 100% @ 500 PSI (3450kPa)
 Minimal Operating Pressure: 7 PSI (48kPa)
 Temperature Rating: See Chart on Pg. 4

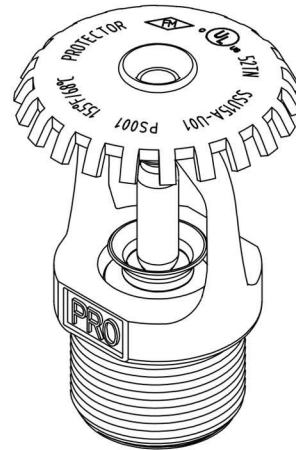

PS001 Upright

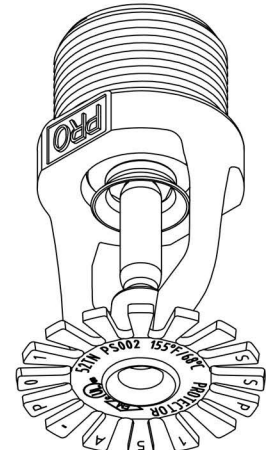

PS002 Pendent

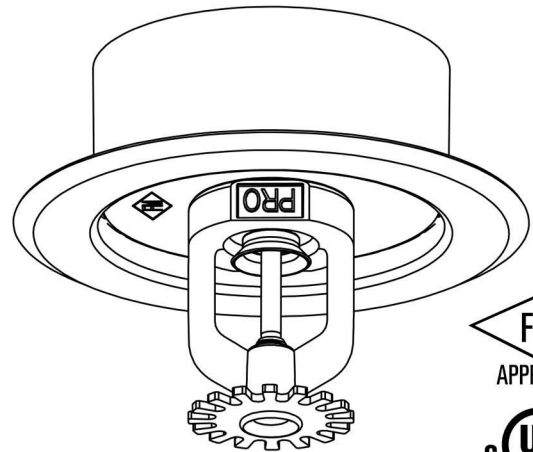

PS004 Recessed Pendent



Maximum Coverage

Standard spray coverage is up to: Light Hazard = 225 square feet (20.9 sq.m); Ordinary Hazard = 130 square feet (12.1 sq. m) per NFPA 13. See Chart on Pg.4 for distribution patterns.

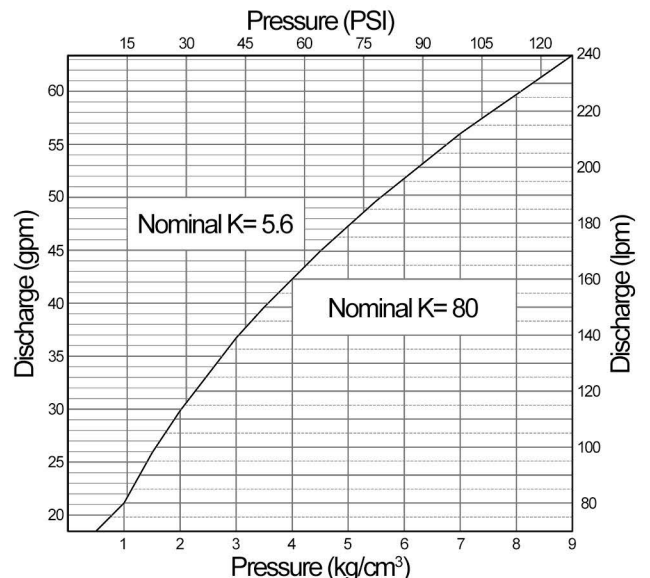

Model A - 5.6 K Factor
Upright, Pendent, Recessed Pendent,
Standard Response, Quick Response

PROTECTOR

Dimensions & Physical Characteristics

Upright Sprinkler (PS001 / PS005)

1 - Frame	Brass
2 - Deflector	Brass
3 - Cap	Brass
4 - Cap Seat	Stainless Steel
5 - Load Screw	Brass
6 - Seal	Bery. Nickel Spring Teflon Tape
7 - Bulb	Norbulb N5 / N3

Pendent Sprinkler (PS002 / PS004)

1 - Frame	Brass
2 - Deflector	Brass
3 - Cap	Brass
4 - Cap Seat	Stainless Steel
5 - Load Screw	Brass
6 - Seal	Bery. Nickel Spring Teflon Tape
7 - Bulb	Norbulb N5 / N3

Recessed Pendent Sprinkler (PS002 / PS004)

Maximum Recessed

Maximum Extension

Model A - 5.6 K Factor

Upright, Pendent, Recessed Pendent, Standard Response, Quick Response

PROTECTOR

Installation

All Protector Sprinklers must be installed according to NFPA 13 Standards. Deviations from these requirements and standards or any alteration to the sprinkler itself will void any warranty made by Protector Safety Company. In addition, installation must also meet local government provisions, codes and standards as applicable. The system piping must be properly sized to insure the minimum required flow rate at the sprinkler. Check for the proper model, style, orifice size and temperature rating prior to installation. Install sprinklers after the piping is in place to avoid mechanical damage, replace any damaged units. Wet pipe systems must be protected from freezing. Upon completion of the installation, the system must be tested per recognized standards. In the event of a thread task, remove the unit, apply new pipe joint compound or tape, and reinstall.

Tool Description

All Protector sprinklers must be installed according to the following. Sprinkler wrenches is a tool specifically designed for installing Protector sprinklers. These special wrenches must be used to provide the proper leverage when tightening the sprinkler and to minimize slippage during installation. Any other wrench may damage the sprinkler. The following wrenches are available for installing Protector sprinklers.

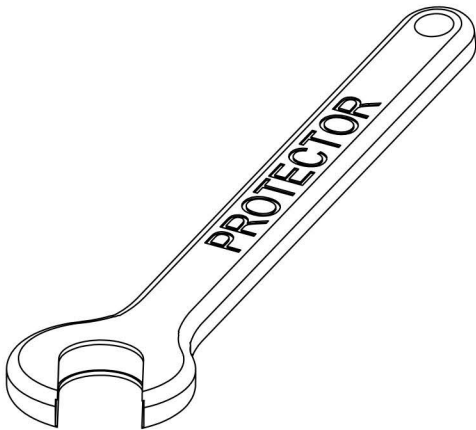

Protector Sprinkler Wrench

Escutcheon Installation

Use Protector escutcheon plate to ensure proper sprinkler distribution and coverage. To install the escutcheon plate on recessed sprinklers, align with it and push or thread over the sprinkler body into the upper support piece, until the outer edge of the escutcheon meets the mounting surface.

Installation Sequence

Step 1. The unit must be installed in the upright position for the Upright Sprinklers, and in the pendent position for the Pendent Sprinkler and Recessed Pendent Sprinkler.
Step 2. Use only a non-hardening pipe joint compound or tape seal. Apply only to the male-threads.
Step 3. Hand tighten the sprinkler into fitting.
Step 4. For Upright and Pendent Sprinklers, use a standard wrench. Tighten the unit into the fitting. A lead-tight joint requires only 150 to 200 kg·cm (14.7 to 19.6 N·m) of torque. Once torque level reach over 300 kg·cm (29.4 N·m) it may distort the orifice seal, resulting in leakage. For exposed piping systems, the sprinkler should be oriented so the frame arms are parallel with the branch line pipe.

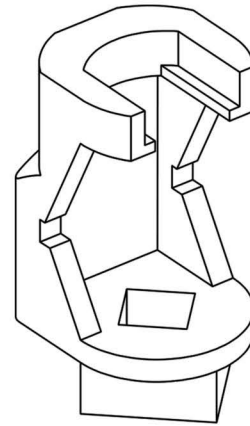

Protector Sprinkler Key

Caution

Do not over-tighten or under-tighten the sprinkler to compensate for inaccurate escutcheon plate adjustment. Protection clips are used to protect its bulb. Please have clip on at all times during transportation.

Maintenance

Sprinklers must never be altered after manufacture. Any alteration such as painting and coating will directly harm the sprinkler and cause malfunctions. Sprinkler in contact with corrosive products should be replaced if they cannot be cleaned completely. Visual inspections are recommended after installation. After installation, an annual close-up inspection will suffice. Inspection and maintenance of fire protection system is the responsibility of the owner. It is recommended that automatic sprinkler system be inspected and tested according to local and/or national regulations.

Model A - 5.6 K Factor
Upright, Pendent, Recessed Pendent,
Standard Response, Quick Response



Approvals & Listings

Type (SIN)	Nominal Size Inches (mm)		K Factor Imperial (SI)	Response	Approvals		
	Thread	Orifice			UL	cUL	FM
Upright (PS001)	1/2 (15)	1/2 (13)	5.6 (80)	Standard	Yes	Yes	Yes
Pendent (PS002)	1/2 (15)	1/2 (13)	5.6 (80)	Standard	Yes	Yes	Yes
Recessed (PS002)	1/2 (15)	1/2 (13)	5.6 (80)	Standard	Yes	Yes	Yes
Upright (PS005)	1/2 (15)	1/2 (13)	5.6 (80)	Quick	Yes	Yes	Yes
Pendent (PS004)	1/2 (15)	1/2 (13)	5.6 (80)	Quick	Yes	Yes	Yes
Recessed (PS004)	1/2 (15)	1/2 (13)	5.6 (80)	Quick	Yes	Yes	Yes

Temperature Ratings

Sprinkler Temperature Classification	Nominal Sprinkler Temperature Rating	NFPA Maximum Ambient (Ceiling) Temperature Allowed	Glass Bulb Color
Ordinary	57°C (135°F)	38°C (100°F)	Orange
	68°C (155°F)	38°C (100°F)	Red
Intermediate	79°C (175°F)	65°C (150°F)	Yellow
	93°C (200°F)	65°C (150°F)	Green
High	141°C (286°F)	107°C (225°F)	Blue
Extra High	182°C (360°F)	149°C (300°F)	Mauve
Open	Open	-	No Bulb

Distribution Trajectory

